

PSS SF 620 | Speed Flaker

Advantages

- Cutting blocks of frozen meat and other foodstuff down to - 25 °C
- Gentle and clean cutting of the product to small, medium or large flakes
- Automatic block pushing towards the cutting drum
- Thruster ensures the optimal block position for quality cutting
- High performance thanks to its modern design
- 7 knives adjustable to 3 cutting thickness
- Tilting safety cover
- Tilting table as the operating personnel workspace
- Polished surfaces
- Complication-free and fast sanitation



PSS SF are designed for the food industry operations for fast cutting of whole frozen meat blocks and other various foodstuff with the temperature down to -25°C. PSS SF ensure gentle and clean product cutting to small, medium and large flakes. PSS SF cutting thickness are in the variant A 3/6/9 mm and in the variant B 14/17/20 mm. The frozen meat blocks and other foodstuff are put on the tilting loading table of PSS SF and they

are automatically pushed towards the cutting drum, while the thruster ensures the optimal block position for clean and quality product cutting. PSS SF achieve a high performance also by the cutting drum design, which processes the blocks of dimensions 600x400x200 mm. There are 7 knives placed on the cutting drum that can be standardly adjustable to 3 cutting thickness.

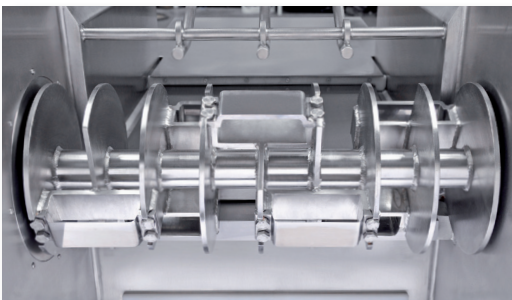

Control

PSS SF are controlled by the control buttons positioned on the machine with an easy access for the operating personnel.

Safety and manipulation

PSS SF are standardly supplied with the tilting safety cover of the cutting area and the cutting drum. The tilting table can be used as the operating personnel workspace for blocks unpacking. PSS SF meet the EU as well as the US regulations.

Hygiene and sanitation

PSS SF are manufactured from the stainless steel AISI 304 and all external and internal surfaces, which come into contact with a product, are polished. The hygienic design of PSS SF takes into account the minimizing of bacteria growth. The tilting safety cover, the tilting table and the perfect sealing enable a complication-free and fast sanitation.

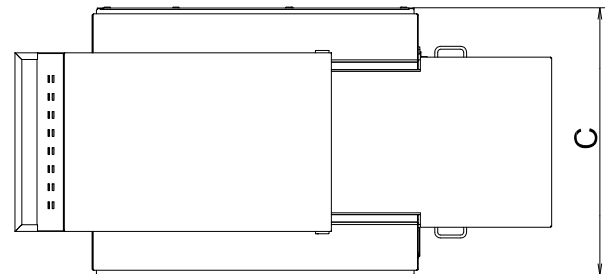
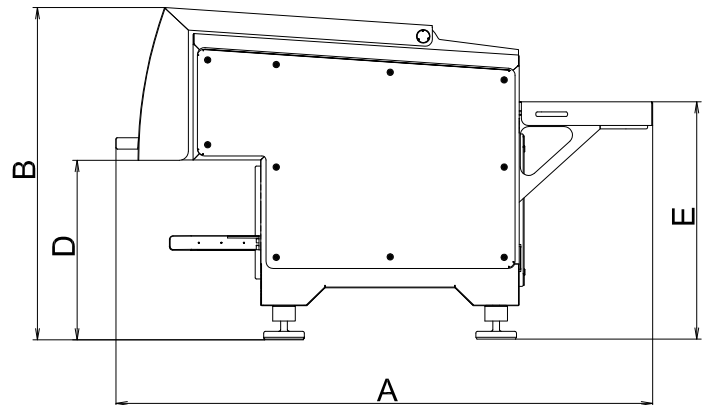

Parameters		PSS SF 620
Input		11 kW
Machine weight		960 kg
Main dimensions	A	2 378 mm
	B	1 470 mm
	C	1 168 mm
	D	BIGBOX 796 mm Manipulation trolley 716 mm
	E	1 052 mm
Capacity (depends on the block size and cutting thickness)		6 000 kg/hour
A) Cutting thickness		3/6/9 mm
B) Cutting thickness		14/17/20 mm
Cutting area dimensions		620 mm x 600 mm x 270 mm
Voltage network		3/PE/N 50 Hz 230/400V TN-C-S
Standardized AC voltage		230/400 V ± 10%
Control voltage		230/24 V AC

Notice:

As a result of continuous process improvement and modernization of our products there may be modifications and changes in characteristics and descriptions of machines. Therefore the manufacturer PSS SVIDNÍK, a.s., reserves the right to change any specifications and technical parameters of its products.